

DATA SHEET

TDA8060TS Satellite ZERO-IF QPSK down-converter

Product specification
Supersedes data of 1999 Aug 30
File under Integrated Circuits, IC02

1999 Nov 11

Satellite ZERO-IF QPSK down-converter

TDA8060TS

FEATURES

- Direct conversion QPSK demodulation (Zero IF)
- 920 to 2200 MHz range
- On-chip loop-controlled 0 or 90° phase shifter
- Variable gain on RF input
- 60 MHz, at -1 dB, bandwidth for baseband I and Q amplifiers
- Local oscillator output to PLL satellite or terrestrial
- 5 V supply voltage.

APPLICATIONS

- Direct Broadcasting Satellite (DBS) QPSK demodulation
- Digital Video Broadcasting (DVB) QPSK demodulation.

GENERAL DESCRIPTION

The direct conversion QPSK demodulator is the front-end receiver dedicated to digital TV broadcasting, satisfying both DVB and DBS TV standards.

The 920 to 2200 MHz wide range oscillator covers American, European and Asian satellite bands as well as the future SMA-TV US standard.

Accurate QPSK demodulation is ensured by the on-chip loop-controlled phase shifter. The Zero-IF concept discards traditional IF filtering and intermediate conversion techniques. It also simplifies the signal path.

The baseband I and Q signal bandwidth only depends, to a certain extent, on the external filter used in the application.

Optimum signal level is guaranteed by a gain-controlled amplifier at the RF input. The GAIN pin sets the gain for both I and Q channels, providing a 30 dB range.

The chip also offers a selectable internal LO prescaler (divide-by-2) and buffer that has been designed to be compatible with the input of a terrestrial or satellite frequency synthesizer.

QUICK REFERENCE DATA

SYMBOL	PARAMETER	MIN.	TYP.	MAX.	UNIT
V_{CC}	supply voltage	4.75	5.00	5.25	V
$\Delta\Phi$	quadrature error	-	-	3	deg
f_{osc}	oscillator frequency	920	-	2200	MHz
$V_{o(p-p)}$	output voltage (peak-to-peak value)	-	0.75	-	V
T_{amb}	ambient temperature	-20	-	+85	°C

ORDERING INFORMATION

TYPE NUMBER	PACKAGE		
	NAME	DESCRIPTION	VERSION
TDA8060TS	SSOP24	plastic shrink small outline package; 24 leads; body width 5.3 mm	SOT340-1

Satellite ZERO-IF QPSK down-converter

TDA8060TS

BLOCK DIAGRAM

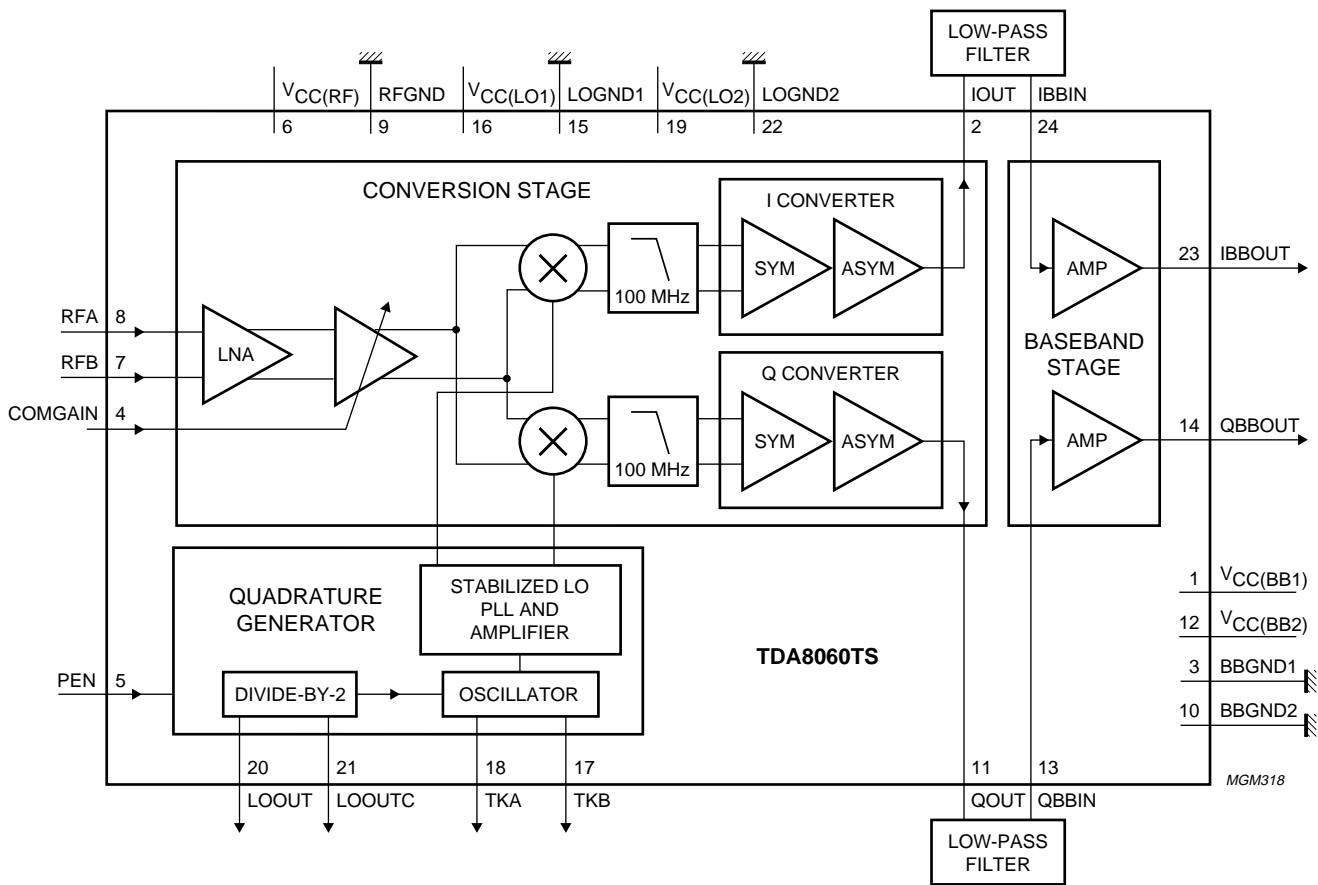

Fig.1 Block diagram.

Satellite ZERO-IF QPSK down-converter

TDA8060TS

PINNING

SYMBOL	PIN	DESCRIPTION
V _{CC(BB1)}	1	supply voltage 1 for baseband circuit (+5 V)
IOUT	2	'I' output from demodulator
BBGND1	3	ground 1 for baseband circuit
COMGAIN	4	RF amplifier gain control input
PEN	5	prescaler enable
V _{CC(RF)}	6	supply voltage for RF circuit (+5 V)
RFB	7	RF signal input B
RFA	8	RF signal input A
RFGND	9	ground for RF circuit
BBGND2	10	ground 2 for baseband circuit
QOUT	11	'Q' output from demodulator
V _{CC(BB2)}	12	supply voltage 2 for baseband circuit (+5 V)
QBBIN	13	'Q' baseband amplifier input
QBBOUT	14	'Q' baseband amplifier output
LOGND1	15	ground 1 for local oscillator circuit
V _{CC(LO1)}	16	supply voltage 1 for local oscillator circuit (+5 V)
TKB	17	tank circuit input B
TKA	18	tank circuit input A
V _{CC(LO2)}	19	supply voltage 2 for local oscillator circuit (+5 V)
LOOUT	20	local oscillator output to synthesizer divided or not according to PEN voltage
LOOUTC	21	
LOGND2	22	ground 2 for local oscillator circuit
IBBOUT	23	'I' baseband amplifier output
IBBIN	24	'I' baseband amplifier input

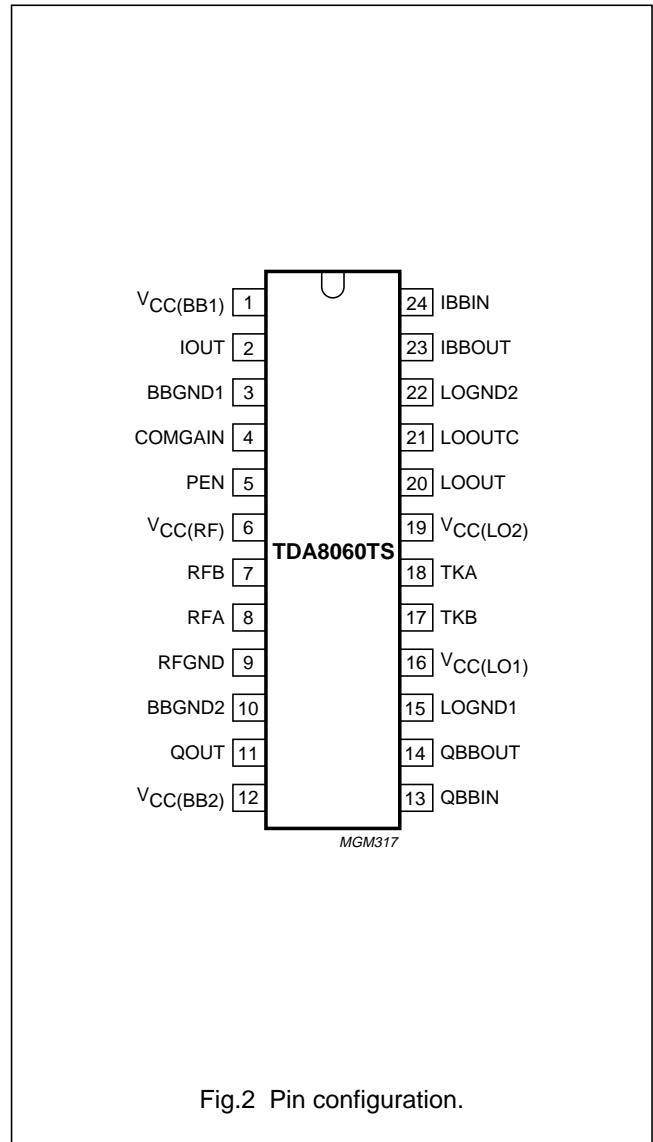

Fig.2 Pin configuration.

Satellite ZERO-IF QPSK down-converter

TDA8060TS

LIMITING VALUES

In accordance with the Absolute Maximum Rating System (IEC 134).

SYMBOL	PARAMETER	MIN.	MAX.	UNIT
V_{CC}	supply voltage	-0.3	+6.0	V
$V_{i(max)}$	maximum input voltage on all pins	-0.3	V_{CC}	V
$t_{sc(max)}$	maximum short-circuit time	-	10	s
T_{amb}	ambient temperature	-20	+85	°C
T_{stg}	storage temperature	-55	+150	°C
T_j	junction temperature	-	150	°C

HANDLING

Inputs and outputs are protected against electrostatic discharge in normal handling. However, to be totally safe, it is desirable to take normal precautions appropriate to handling MOS devices.

THERMAL CHARACTERISTICS

SYMBOL	PARAMETER	CONDITIONS	VALUE	UNIT
$R_{th(j-a)}$	thermal resistance from junction to ambient	in free air	120	K/W

DC CHARACTERISTICS

$T_{amb} = 25\text{ °C}$; $V_{CC} = 5\text{ V}$; unless otherwise specified.

SYMBOL	PARAMETER	CONDITIONS	MIN.	TYP.	MAX.	UNIT
V_{CC}	supply voltage		4.75	5.00	5.25	V
I_{CC}	supply current	PEN = 5 V	63	73	83	mA
		PEN = 0 V	60	70	80	mA
Conversion stage						
$V_{I(RFA)}$	DC input voltage on pin RFA		-	0.9	-	V
$V_{I(RFB)}$	DC input voltage on pin RFB		-	0.9	-	V
$V_{O(IOUT)}$	DC output voltage on pin IOUT		-	2.0	-	V
$V_{O(QOUT)}$	DC output voltage on pin QOUT		-	2.0	-	V
Quadrature generator						
$V_{O(LOOUT)}$	DC output voltage on pin LOOUT		-	4.7	-	V
$V_{O(LOOUTC)}$	DC output voltage on pin LOOUTC		-	4.7	-	V
Baseband stage						
$V_{I(IBBIN)}$	DC input voltage on pin IBBIN		-	2.5	-	V
$V_{I(QBBIN)}$	DC input voltage on pin QBBIN		-	2.5	-	V
$V_{O(IBBOUT)}$	DC output voltage on pin IBBOUT		-	2.5	-	V
$V_{O(QBBOUT)}$	DC output voltage on pin QBBOUT		-	2.5	-	V

Satellite ZERO-IF QPSK down-converter

TDA8060TS

AC CHARACTERISTICS

$T_{amb} = 25\text{ }^{\circ}\text{C}$; $V_{CC} = 5\text{ V}$; unless otherwise specified.

SYMBOL	PARAMETER	CONDITIONS	MIN.	TYP.	MAX.	UNIT
Quadrature generator						
f_{osc}	oscillator frequency range		920	–	2200	MHz
ΦN_{osc}	oscillator phase noise	at 10 kHz offset; note 1	–	–80	–75	dBc/Hz
$ \Delta\Phi $	absolute quadrature error	note 2	–	0	3	deg
f_{LOOUT}	output frequency	$V_{PEN} = 0\text{ V}$	–	f_{osc}	–	MHz
		$V_{PEN} = V_{CC}$	–	$\frac{1}{2}f_{osc}$	–	MHz
$V_{o(diff)(LOOUT)}$	differential output voltage at pin LOOUT	$R_L = 100\ \Omega$ differential	–30	–22	–	dBm
$ Z_{o(diff)(LOOUT)} $	differential output impedance at pin LOOUT		–	60	–	Ω
Conversion stage						
$R_{i(diff)}$	series real part of differential input impedance at pins RFA and RFB	note 3	–	34	–	Ω
$L_{i(diff)}$	series inductance of differential input impedance at pins RFA and RFB	note 3	–	5	–	nH
$P_{i(max)}$	maximum input power per channel		–	–22	–	dBm
$P_{i(min)}$	minimum input power per channel		–	–52	–	dBm
$\Delta G_V/\Delta V_{(slope)}$	AGC slope	at $G_V(RF-IOUT)_{(min)}$	–	30	43	dB/V
$\Delta G_V(I-Q)$	voltage gain mismatch between I and Q		–	–	1	dB
$\Delta t_{d(g)}(RF-IOUT)$	group delay variation per channel (40 MHz) from RF input to pin IOUT		–	0.5	2	ns
$\Delta t_{d(g)}(RF-QOUT)$	group delay variation per channel (40 MHz) from RF input to pin QOUT		–	0.5	2	ns
$t_{d(g)}(I-Q)(40)$	group delay mismatch per channel (40 MHz) between I and Q		–	0	0.5	ns
$B_{(-1dB)}(RF-IOUT)$	channel –1 dB bandwidth from RF input to pin IOUT		40	50	–	MHz
$B_{(-1dB)}(RF-QOUT)$	channel –1 dB bandwidth from RF input to pin QOUT		40	50	–	MHz
$B_{(-3dB)}(RF-IOUT)$	channel –3 dB bandwidth from RF input to pin IOUT		70	80	–	MHz
$B_{(-3dB)}(RF-QOUT)$	channel –3 dB bandwidth from RF input to pin QOUT		70	80	–	MHz
$Z_{o(IOUT)}$	output impedance at pin IOUT		–	65	–	Ω
$Z_{o(QOUT)}$	output impedance at pin QOUT		–	65	–	Ω
$V_{o(IOUT)}$	nominal output voltage level at pin IOUT	per channel	–	25	–	dBmV
$V_{o(QOUT)}$	nominal output voltage level at pin QOUT	per channel	–	25	–	dBmV
$R_{oL(IOUT)}$	resistive load at pin IOUT		400	–	–	Ω
$R_{oL(QOUT)}$	resistive load at pin QOUT		400	–	–	Ω

Satellite ZERO-IF QPSK down-converter

TDA8060TS

SYMBOL	PARAMETER	CONDITIONS	MIN.	TYP.	MAX.	UNIT
SYMMETRICAL RF INPUT (Fig.3)						
$G_{V(RF-IOUT)(min)}$	minimum voltage gain from RF input to pin IOUT	$V_{AGC} = 0.1 \times V_{CC}$; note 4	–	–	–1	dB
$G_{V(RF-IOUT)(max)}$	maximum voltage gain from RF input to pin IOUT	$V_{AGC} = 0.9 \times V_{CC}$; note 4	28	29	–	dB
$G_{V(RF-QOUT)(min)}$	minimum voltage gain from RF input to pin QOUT	$V_{AGC} = 0.1 \times V_{CC}$; note 4	–	–	–1	dB
$G_{V(RF-QOUT)(max)}$	maximum voltage gain from RF input to pin QOUT	$V_{AGC} = 0.9 \times V_{CC}$; note 4	28	29	–	dB
$IP_{3i(I)}$	I 3rd-order interception point at RF input		1	4	–	dBm
$IP_{2i(I)}$	I 2nd-order interception point at RF input		12	15	–	dBm
$IP_{3i(Q)}$	Q 3rd-order interception point at RF input		1	4	–	dBm
$IP_{2i(Q)}$	Q 2nd-order interception point at RF input		12	15	–	dBm
F_i	noise figure at maximum gain	$V_{AGC} = 0.9 \times V_{CC}$; $Z_{source} = 50 \Omega$	–	12	15	dB
ASYMMETRICAL RF INPUT (Fig.4)						
$G_{V(RF-IOUT)(min)}$	minimum voltage gain from RF input to pin IOUT	$V_{AGC} = 0.1 \times V_{CC}$; note 5	–	–	–1	dB
$G_{V(RF-IOUT)(max)}$	maximum voltage gain from RF input to pin IOUT	$V_{AGC} = 0.9 \times V_{CC}$; note 5	–	29	–	dB
$G_{V(RF-QOUT)(min)}$	minimum voltage gain from RF input to pin QOUT	$V_{AGC} = 0.1 \times V_{CC}$; note 5	–	–	–1	dB
$G_{V(RF-QOUT)(max)}$	maximum voltage gain from RF input to pin QOUT	$V_{AGC} = 0.9 \times V_{CC}$; note 5	–	29	–	dB
$IP_{3i(I)}$	I 3rd-order interception point at RF input		–	3	–	dBm
$IP_{2i(I)}$	I 2nd-order interception point at RF input		–	15	–	dBm
$IP_{3i(Q)}$	Q 3rd-order interception point at RF input		–	3	–	dBm
$IP_{2i(Q)}$	Q 2nd-order interception point at RF input		–	15	–	dBm
F_i	noise figure at maximum gain	$V_{AGC} = 0.9 \times V_{CC}$; $Z_{source} = 50 \Omega$	–	13	–	dB
Baseband stages						
Z_i	input impedance		–	10	–	k Ω
V_i	nominal input voltage level	per channel	–	25	–	dBmV
NTX_i	number of channels at input		–	2	–	–
$G_{V(IBBIN-IBBOUT)}$	voltage gain from pin IBBIN to pin IBBOUT		19	20	22	dB
$G_{V(QBBIN-QBBOUT)}$	voltage gain from pin QBBIN to pin QBBOUT		19	20	22	dB
$G_{V(I-Q)}$	voltage gain mismatch between I and Q		–	0	1	dB
IP_{3i}	3rd-order interception point at IQBBIN input		54	59	–	dBmV
IP_{2i}	2nd-order interception point at IQBBIN input		72	79	–	dBmV
$\Delta t_{d(g)(40)}$	group delay variation in 40 MHz bandwidth		–	0.5	2	ns
$t_{d(g)(I-Q)(40)}$	group delay mismatch in 40 MHz band between I and Q		–	0.5	2	ns

Satellite ZERO-IF QPSK down-converter

TDA8060TS

SYMBOL	PARAMETER	CONDITIONS	MIN.	TYP.	MAX.	UNIT
$B_{(-1dB)}$	channel -1 dB bandwidth		40	65	–	MHz
$B_{(-3dB)}$	channel -3 dB bandwidth		70	100	–	MHz
Z_o	output impedance		–	50	–	Ω
$V_{o(p-p)}$	nominal output voltage level		–	750	–	mV
$R_{o(L)}$	resistive load at output		400	–	–	Ω
Overall with a 100 nF capacitor instead of LP1 and LP2						
$t_{d(g)(I-Q)(40)}$	group delay mismatch in 40 MHz band between I and Q		–	0.5	2	ns
$t_{d(g)(I-Q)(R40)}$	group delay ripple in 40 MHz band for I or Q		–	0.5	1	ns
$G_{v(I-Q)(40)}$	voltage gain mismatch in 40 MHz band between I and Q		–	–	1	dB
$G_{R(I-Q)(40)}$	voltage gain ripple in 40 MHz band for I or Q		–	–	1	dB
SYMMETRICAL RF INPUT						
$G_{v(RF-IBBOUT)(min)}$	minimum voltage gain from RF input to pin IBBOUT	$V_{AGC} = 0.1 \times V_{CC}$	–	–	19	dB
$G_{v(RF-IBBOUT)(max)}$	maximum voltage gain from RF input to pin IBBOUT	$V_{AGC} = 0.9 \times V_{CC}$	48	49	–	dB
$G_{v(RF-QBBOUT)(min)}$	minimum voltage gain from RF input to pin QBBOUT	$V_{AGC} = 0.1 \times V_{CC}$	–	–	19	dB
$G_{v(RF-QBBOUT)(max)}$	maximum voltage gain from RF input to pin QBBOUT	$V_{AGC} = 0.9 \times V_{CC}$	48	49	–	dB
F_i	noise figure at maximum gain	$V_{AGC} = 0.9 \times V_{CC};$ $Z_{source} = 50 \Omega$	–	13	16	dB
ASYMMETRICAL RF INPUT						
$G_{v(RF-IBBOUT)(min)}$	minimum voltage gain from RF input to pin IBBOUT	$V_{AGC} = 0.1 \times V_{CC}$	–	–	19	dB
$G_{v(RF-IBBOUT)(max)}$	maximum voltage gain from RF input to pin IBBOUT	$V_{AGC} = 0.9 \times V_{CC}$	–	49	–	dB
$G_{v(RF-QBBOUT)(min)}$	minimum voltage gain from RF input to pin QBBOUT	$V_{AGC} = 0.1 \times V_{CC}$	–	–	19	dB
$G_{v(RF-QBBOUT)(max)}$	maximum voltage gain from RF input to pin QBBOUT	$V_{AGC} = 0.9 \times V_{CC}$	–	49	–	dB
F_i	noise figure at maximum gain	$V_{AGC} = 0.9 \times V_{CC};$ $Z_{source} = 50 \Omega$	–	14	–	dB

Notes

1. Measured in baseband (at pin IOUT or pin QOUT) on a carrier at 2 MHz and 25 dBmV.
2. Quadrature error with respect to 90° .
3. The differential input impedance of the IC is 34Ω in series with the IC pins which give an inductance of 5 nH. For optimum performance, this inductance should be cancelled by a matching network. Coupling capacitors of 1 pF give an acceptable result.
4. Gain = $V_{o(dB)} - V_{i(dB)}$ (see Fig.3). Gain for symmetrical RF input
5. Gain = $V_{o(dB)} - V_{i(dB)}$ (see Fig.3). Gain for asymmetrical RF input

Satellite ZERO-IF QPSK down-converter

TDA8060TS

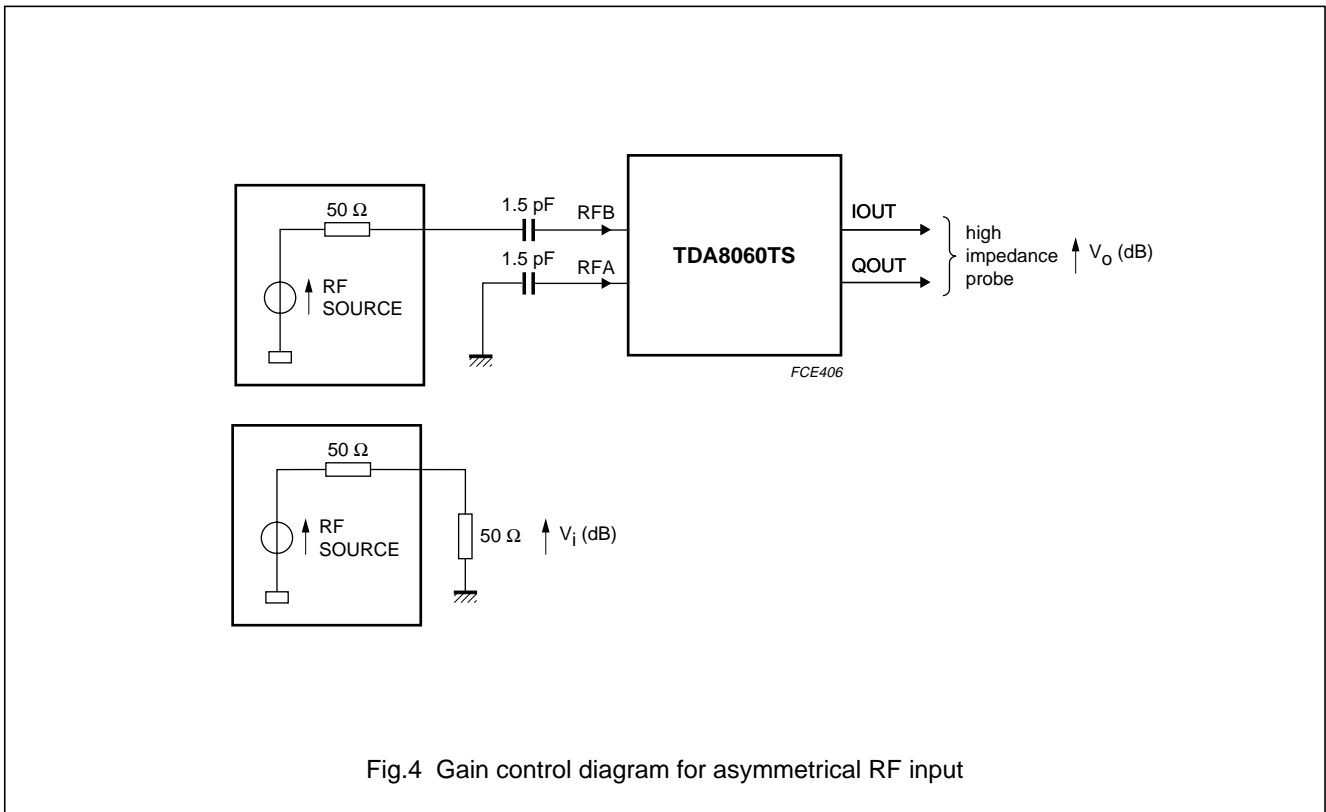
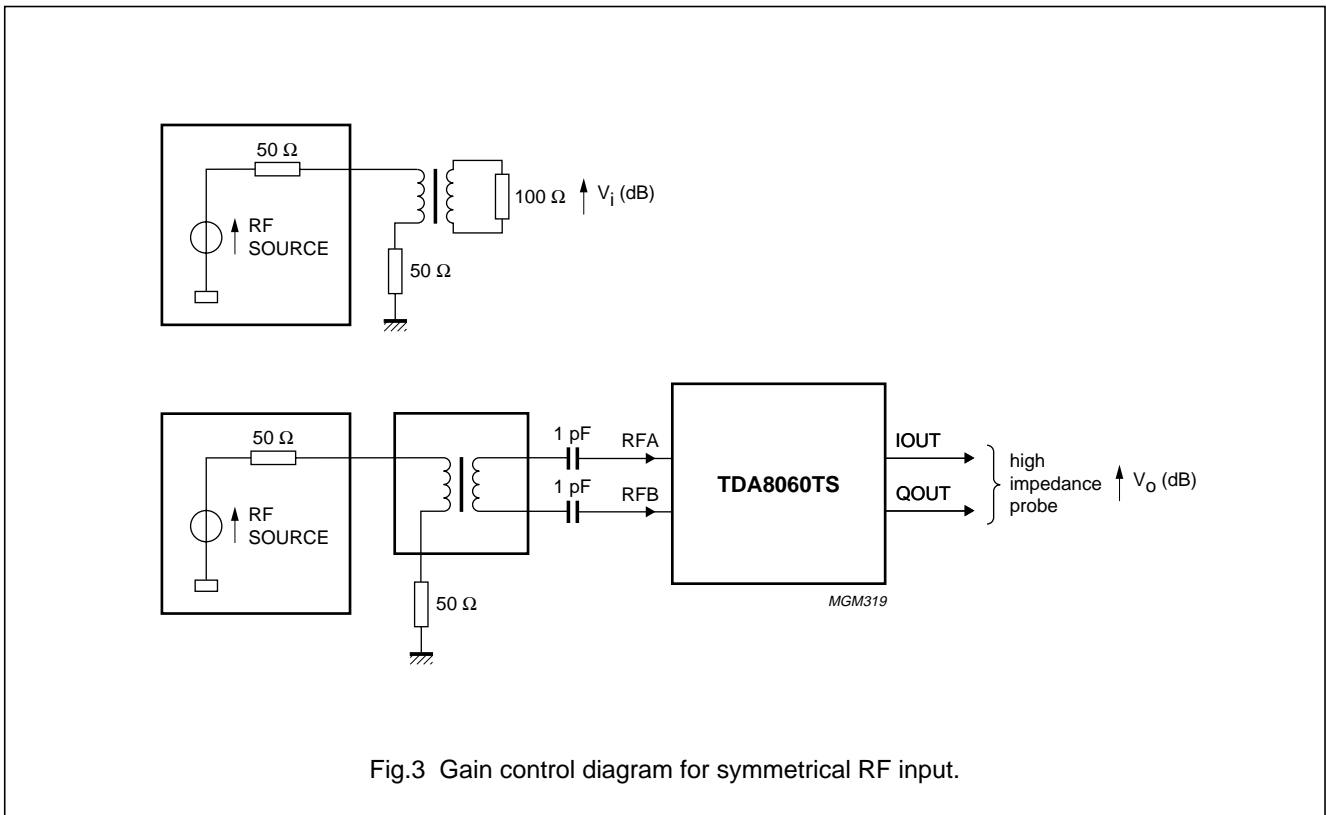

Satellite ZERO-IF QPSK down-converter**TDA8060TS**

APPLICATION INFORMATION

Close attention should be paid to the design of the external tank circuit of the VCO so that it covers the 920 to 2200 MHz frequency range. Both series 6 Ω resistors kill all parasitic oscillations that could alter this frequency range. The BB835 Siemens varicap diodes are mentioned because they provide the highest C_{\max}/C_{\min} ratio as well as the least parasitic elements in our frequency range. The U-shaped inductance can be printed with a total length of approximately 20 mm.

Filters LP1 and LP2 are not detailed in this data sheet because their design only depends on the global system. As the TDA8060 has been designed to be compatible with DVB, DSS and Asian DVB, the cut-off frequencies and the tolerance in group delay, the orders of the filters cannot be globally established.

Nevertheless, TDA8060 internally filters the baseband at 100 MHz and the nominal levels at inputs and outputs mentioned in the specification table should be respected. The input impedance of LP1 and LP2 must exceed 400 Ω to avoid signal distortion.

The converter outputs (pin IOOUT and pin QOUT) must be AC-coupled via the low-pass filter to the baseband amplifiers inputs (pin IBBIN and pin QBBIN). Because of the high impedance at pin IQBBIN, a 100 nF capacitor gives a high-pass frequency of 160 Hz.

Satellite ZERO-IF QPSK down-converter

TDA8060TS

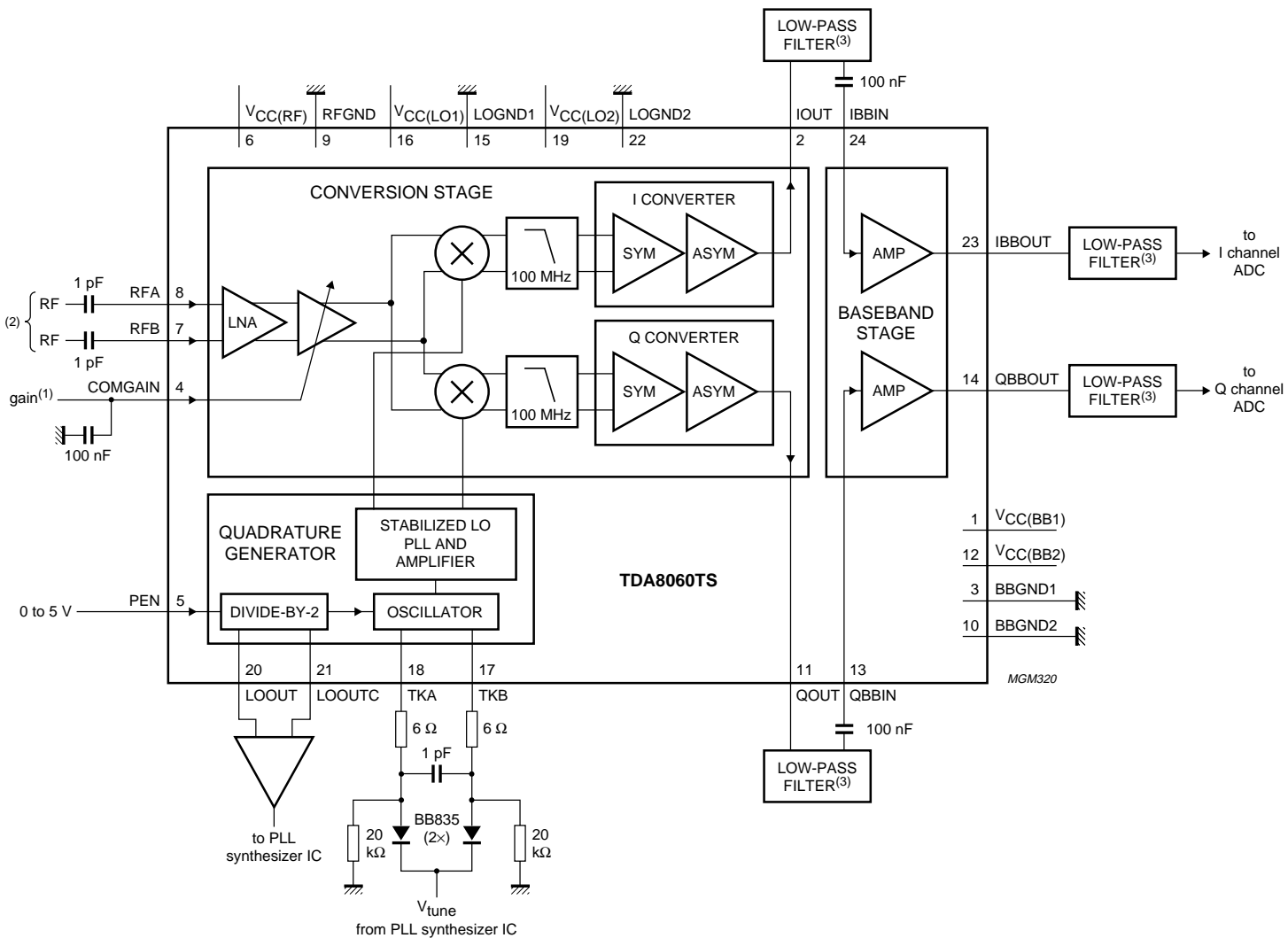

- (1) Gain control voltage; minimum gain at $0.1 \times V_{CC}$, maximum gain at $0.9 \times V_{CC}$; 30 dB range.
- (2) Differential RF input 950 to 2200 MHz; level = -22 to -52 dBm per channel.
- (3) The filter input impedance is 400 Ω minimum.

Fig.5 Application diagram.

Satellite ZERO-IF QPSK down-converter

TDA8060TS

PACKAGE OUTLINE

SSOP24: plastic shrink small outline package; 24 leads; body width 5.3 mm

SOT340-1

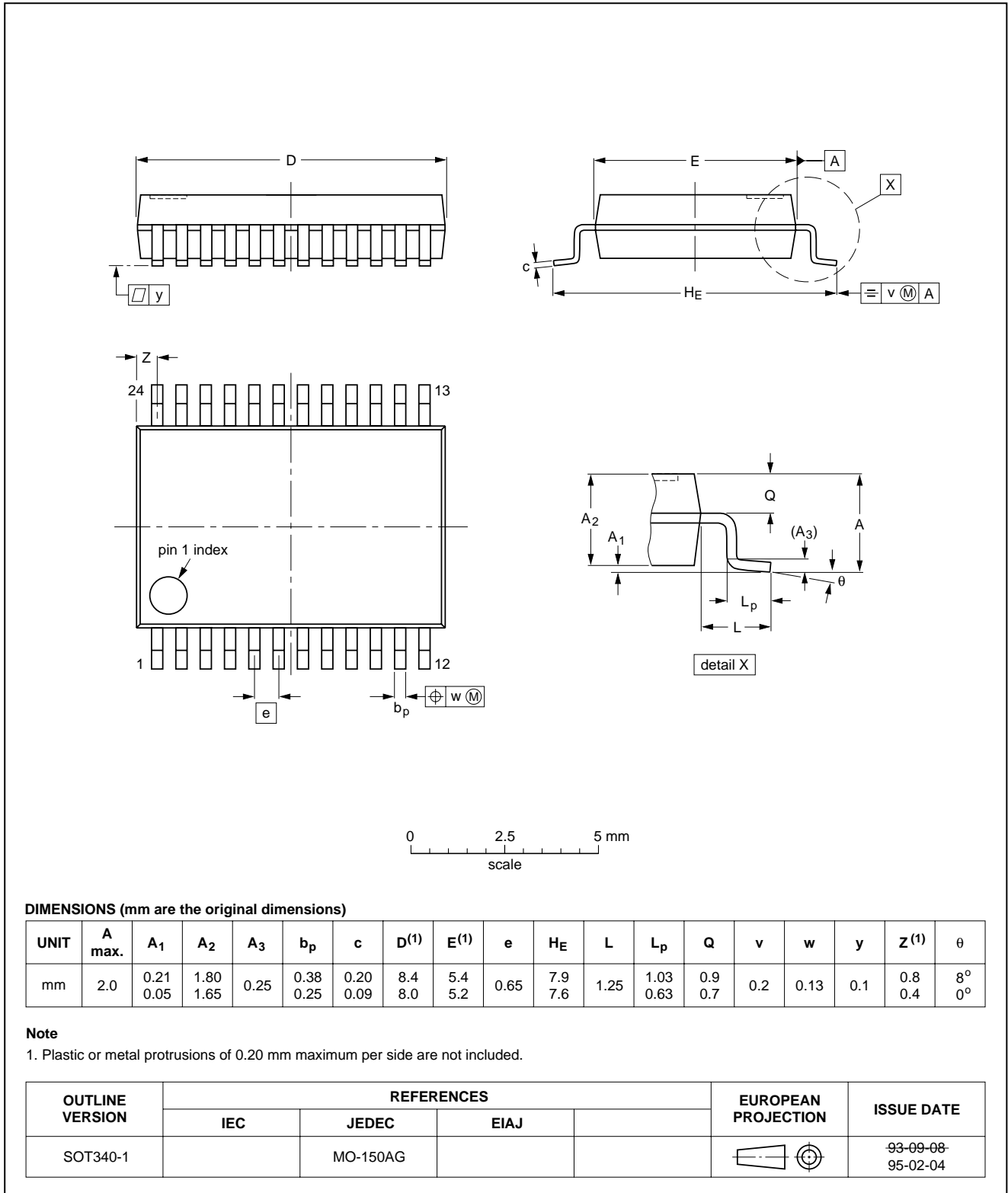

Satellite ZERO-IF QPSK down-converter

TDA8060TS

SOLDERING

Introduction to soldering surface mount packages

This text gives a very brief insight to a complex technology. A more in-depth account of soldering ICs can be found in our *"Data Handbook IC26; Integrated Circuit Packages"* (document order number 9398 652 90011).

There is no soldering method that is ideal for all surface mount IC packages. Wave soldering is not always suitable for surface mount ICs, or for printed-circuit boards with high population densities. In these situations reflow soldering is often used.

Reflow soldering

Reflow soldering requires solder paste (a suspension of fine solder particles, flux and binding agent) to be applied to the printed-circuit board by screen printing, stencilling or pressure-syringe dispensing before package placement.

Several methods exist for reflowing; for example, infrared/convection heating in a conveyor type oven. Throughput times (preheating, soldering and cooling) vary between 100 and 200 seconds depending on heating method.

Typical reflow peak temperatures range from 215 to 250 °C. The top-surface temperature of the packages should preferably be kept below 230 °C.

Wave soldering

Conventional single wave soldering is not recommended for surface mount devices (SMDs) or printed-circuit boards with a high component density, as solder bridging and non-wetting can present major problems.

To overcome these problems the double-wave soldering method was specifically developed.

If wave soldering is used the following conditions must be observed for optimal results:

- Use a double-wave soldering method comprising a turbulent wave with high upward pressure followed by a smooth laminar wave.
- For packages with leads on two sides and a pitch (e):
 - larger than or equal to 1.27 mm, the footprint longitudinal axis is **preferred** to be parallel to the transport direction of the printed-circuit board;
 - smaller than 1.27 mm, the footprint longitudinal axis **must** be parallel to the transport direction of the printed-circuit board.

The footprint must incorporate solder thieves at the downstream end.

- For packages with leads on four sides, the footprint must be placed at a 45° angle to the transport direction of the printed-circuit board. The footprint must incorporate solder thieves downstream and at the side corners.

During placement and before soldering, the package must be fixed with a droplet of adhesive. The adhesive can be applied by screen printing, pin transfer or syringe dispensing. The package can be soldered after the adhesive is cured.

Typical dwell time is 4 seconds at 250 °C.

A mildly-activated flux will eliminate the need for removal of corrosive residues in most applications.

Manual soldering

Fix the component by first soldering two diagonally-opposite end leads. Use a low voltage (24 V or less) soldering iron applied to the flat part of the lead. Contact time must be limited to 10 seconds at up to 300 °C.

When using a dedicated tool, all other leads can be soldered in one operation within 2 to 5 seconds between 270 and 320 °C.

Satellite ZERO-IF QPSK down-converter

TDA8060TS

Suitability of surface mount IC packages for wave and reflow soldering methods

PACKAGE	SOLDERING METHOD	
	WAVE	REFLOW ⁽¹⁾
BGA, SQFP	not suitable	suitable
HLQFP, HSQFP, HSOP, HTSSOP, SMS	not suitable ⁽²⁾	suitable
PLCC ⁽³⁾ , SO, SOJ	suitable	suitable
LQFP, QFP, TQFP	not recommended ⁽³⁾⁽⁴⁾	suitable
SSOP, TSSOP, VSO	not recommended ⁽⁵⁾	suitable

Notes

- All surface mount (SMD) packages are moisture sensitive. Depending upon the moisture content, the maximum temperature (with respect to time) and body size of the package, there is a risk that internal or external package cracks may occur due to vaporization of the moisture in them (the so called popcorn effect). For details, refer to the Drypack information in the "Data Handbook IC26; Integrated Circuit Packages; Section: Packing Methods".
- These packages are not suitable for wave soldering as a solder joint between the printed-circuit board and heatsink (at bottom version) can not be achieved, and as solder may stick to the heatsink (on top version).
- If wave soldering is considered, then the package must be placed at a 45° angle to the solder wave direction. The package footprint must incorporate solder thieves downstream and at the side corners.
- Wave soldering is only suitable for LQFP, TQFP and QFP packages with a pitch (e) equal to or larger than 0.8 mm; it is definitely not suitable for packages with a pitch (e) equal to or smaller than 0.65 mm.
- Wave soldering is only suitable for SSOP and TSSOP packages with a pitch (e) equal to or larger than 0.65 mm; it is definitely not suitable for packages with a pitch (e) equal to or smaller than 0.5 mm.

DEFINITIONS

Data sheet status	
Objective specification	This data sheet contains target or goal specifications for product development.
Preliminary specification	This data sheet contains preliminary data; supplementary data may be published later.
Product specification	This data sheet contains final product specifications.
Limiting values	
Limiting values given are in accordance with the Absolute Maximum Rating System (IEC 134). Stress above one or more of the limiting values may cause permanent damage to the device. These are stress ratings only and operation of the device at these or at any other conditions above those given in the Characteristics sections of the specification is not implied. Exposure to limiting values for extended periods may affect device reliability.	
Application information	
Where application information is given, it is advisory and does not form part of the specification.	

LIFE SUPPORT APPLICATIONS

These products are not designed for use in life support appliances, devices, or systems where malfunction of these products can reasonably be expected to result in personal injury. Philips customers using or selling these products for use in such applications do so at their own risk and agree to fully indemnify Philips for any damages resulting from such improper use or sale.

Satellite ZERO-IF QPSK down-converter

TDA8060TS

NOTES

Philips Semiconductors – a worldwide company

Argentina: see South America

Australia: 3 Figtree Drive, HOME BUSH, NSW 2140,
Tel. +61 2 9704 8141, Fax. +61 2 9704 8139

Austria: Computerstr. 6, A-1101 WIEN, P.O. Box 213,
Tel. +43 1 60 101 1248, Fax. +43 1 60 101 1210

Belarus: Hotel Minsk Business Center, Bld. 3, r. 1211, Volodarski Str. 6,
220050 MINSK, Tel. +375 172 20 0733, Fax. +375 172 20 0773

Belgium: see The Netherlands

Brazil: see South America

Bulgaria: Philips Bulgaria Ltd., Energoproject, 15th floor,
51 James Bourchier Blvd., 1407 SOFIA,
Tel. +359 2 68 9211, Fax. +359 2 68 9102

Canada: PHILIPS SEMICONDUCTORS/COMPONENTS,
Tel. +1 800 234 7381, Fax. +1 800 943 0087

China/Hong Kong: 501 Hong Kong Industrial Technology Centre,
72 Tat Chee Avenue, Kowloon Tong, HONG KONG,
Tel. +852 2319 7888, Fax. +852 2319 7700

Colombia: see South America

Czech Republic: see Austria

Denmark: Sydhavnsgade 23, 1780 COPENHAGEN V,
Tel. +45 33 29 3333, Fax. +45 33 29 3905

Finland: Sinikalliontie 3, FIN-02630 ESPOO,
Tel. +358 9 615 800, Fax. +358 9 6158 0920

France: 51 Rue Carnot, BP317, 92156 SURESNES Cedex,
Tel. +33 1 4099 6161, Fax. +33 1 4099 6427

Germany: Hammerbrookstraße 69, D-20097 HAMBURG,
Tel. +49 40 2353 60, Fax. +49 40 2353 6300

Hungary: see Austria

India: Philips INDIA Ltd, Band Box Building, 2nd floor,
254-D, Dr. Annie Besant Road, Worli, MUMBAI 400 025,
Tel. +91 22 493 8541, Fax. +91 22 493 0966

Indonesia: PT Philips Development Corporation, Semiconductors Division,
Gedung Philips, Jl. Buncit Raya Kav.99-100, JAKARTA 12510,
Tel. +62 21 794 0040 ext. 2501, Fax. +62 21 794 0080

Ireland: Newstead, Clonskeagh, DUBLIN 14,
Tel. +353 1 7640 000, Fax. +353 1 7640 200

Israel: RAPAC Electronics, 7 Kehilat Saloniki St, PO Box 18053,
TEL AVIV 61180, Tel. +972 3 645 0444, Fax. +972 3 649 1007

Italy: PHILIPS SEMICONDUCTORS, Via Casati, 23 - 20052 MONZA (MI),
Tel. +39 039 203 6838, Fax +39 039 203 6800

Japan: Philips Bldg 13-37, Kohnan 2-chome, Minato-ku,
TOKYO 108-8507, Tel. +81 3 3740 5130, Fax. +81 3 3740 5057

Korea: Philips House, 260-199 Itaewon-dong, Yongsan-ku, SEOUL,
Tel. +82 2 709 1412, Fax. +82 2 709 1415

Malaysia: No. 76 Jalan Universiti, 46200 PETALING JAYA, SELANGOR,
Tel. +60 3 750 5214, Fax. +60 3 757 4880

Mexico: 5900 Gateway East, Suite 200, EL PASO, TEXAS 79905,
Tel. +9-5 800 234 7381, Fax +9-5 800 943 0087

Middle East: see Italy

Netherlands: Postbus 90050, 5600 PB EINDHOVEN, Bldg. VB,
Tel. +31 40 27 82785, Fax. +31 40 27 88399

New Zealand: 2 Wagener Place, C.P.O. Box 1041, AUCKLAND,
Tel. +64 9 849 4160, Fax. +64 9 849 7811

Norway: Box 1, Manglerud 0612, OSLO,
Tel. +47 22 74 8000, Fax. +47 22 74 8341

Pakistan: see Singapore

Philippines: Philips Semiconductors Philippines Inc.,
106 Valero St. Salcedo Village, P.O. Box 2108 MCC, MAKATI,
Metro MANILA, Tel. +63 2 816 6380, Fax. +63 2 817 3474

Poland: Al.Jerozolimskie 195 B, 02-222 WARSAW,
Tel. +48 22 5710 000, Fax. +48 22 5710 001

Portugal: see Spain

Romania: see Italy

Russia: Philips Russia, Ul. Usatcheva 35A, 119048 MOSCOW,
Tel. +7 095 755 6918, Fax. +7 095 755 6919

Singapore: Lorong 1, Toa Payoh, SINGAPORE 319762,
Tel. +65 350 2538, Fax. +65 251 6500

Slovakia: see Austria

Slovenia: see Italy

South Africa: S.A. PHILIPS Pty Ltd., 195-215 Main Road Martindale,
2092 JOHANNESBURG, P.O. Box 58088 Newville 2114,
Tel. +27 11 471 5401, Fax. +27 11 471 5398

South America: Al. Vicente Pinzon, 173, 6th floor,
04547-130 SÃO PAULO, SP, Brazil,
Tel. +55 11 821 2333, Fax. +55 11 821 2382

Spain: Balmes 22, 08007 BARCELONA,
Tel. +34 93 301 6312, Fax. +34 93 301 4107

Sweden: Kottbygatan 7, Akalla, S-16485 STOCKHOLM,
Tel. +46 8 5985 2000, Fax. +46 8 5985 2745

Switzerland: Allmendstrasse 140, CH-8027 ZÜRICH,
Tel. +41 1 488 2741 Fax. +41 1 488 3263

Taiwan: Philips Semiconductors, 6F, No. 96, Chien Kuo N. Rd., Sec. 1,
TAIPEI, Taiwan Tel. +886 2 2134 2886, Fax. +886 2 2134 2874

Thailand: PHILIPS ELECTRONICS (THAILAND) Ltd.,
209/2 Sanpavuth-Bangna Road Prakanong, BANGKOK 10260,
Tel. +66 2 745 4090, Fax. +66 2 398 0793

Turkey: Yukari Dudullu, Org. San. Blg., 2.Cad. Nr. 28 81260 Umraniye,
ISTANBUL, Tel. +90 216 522 1500, Fax. +90 216 522 1813

Ukraine: PHILIPS UKRAINE, 4 Patrice Lumumba str., Building B, Floor 7,
252042 KIEV, Tel. +380 44 264 2776, Fax. +380 44 268 0461

United Kingdom: Philips Semiconductors Ltd., 276 Bath Road, Hayes,
MIDDLESEX UB3 5BX, Tel. +44 208 730 5000, Fax. +44 208 754 8421

United States: 811 East Arques Avenue, SUNNYVALE, CA 94088-3409,
Tel. +1 800 234 7381, Fax. +1 800 943 0087

Uruguay: see South America

Vietnam: see Singapore

Yugoslavia: PHILIPS, Trg N. Pasica 5/v, 11000 BEOGRAD,
Tel. +381 11 62 5344, Fax.+381 11 63 5777

For all other countries apply to: Philips Semiconductors,
International Marketing & Sales Communications, Building BE-p, P.O. Box 218,
5600 MD EINDHOVEN, The Netherlands, Fax. +31 40 27 24825

Internet: <http://www.semiconductors.philips.com>

© Philips Electronics N.V. 1999

SCA 68

All rights are reserved. Reproduction in whole or in part is prohibited without the prior written consent of the copyright owner.

The information presented in this document does not form part of any quotation or contract, is believed to be accurate and reliable and may be changed without notice. No liability will be accepted by the publisher for any consequence of its use. Publication thereof does not convey nor imply any license under patent- or other industrial or intellectual property rights.

Printed in The Netherlands

545004/25/04/pp16

Date of release: 1999 Nov 11

Document order number: 9397 750 06554

Let's make things better.

**Philips
Semiconductors**



PHILIPS

This datasheet has been download from:

www.datasheetcatalog.com

Datasheets for electronics components.